

DETAIL VIEW

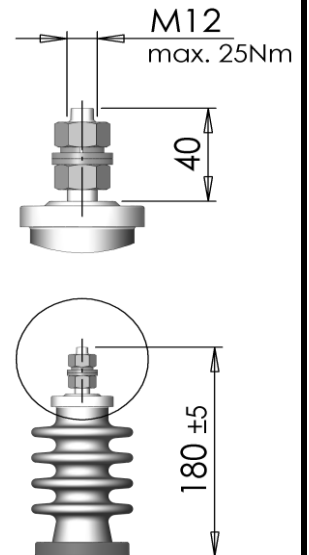

Total creepage [mm]	190
Air-distance [mm]	125
Dry-flashover [kV]	65
Wet-flashover [kV]	40
Drywithstand [kV]	38
Wetwithstand [kV]	28
Impulse voltage [kV]	75

U_N [kV]	7,2	DISCHARGE	75V/600s (3x6,8M Ω)	CONNECTION	Y
Q_N [kvar]	250	WEIGHT [kg]	38	CASE MATERIAL	Stainless steel
C_N [μ F]	3x 15,35 (-5/+10%)	LIQUID CAP. [kg]	10,8	DIMENSIONS:	
f_N [Hz]	50	STANDARD	IEC 60871-1/05	A [mm]	145
I_N [A]	20,0	INT. FUSES	NO	B [mm]	550
BIL [kV]	20/60	SIDE BRACKETS	YES	C [mm]	770
TEMP. CAT.	-40/C	BOTTOM BRACKETS	YES	D [mm]	100
LIQUID	M-DBT (NON PCB)			DRAWN: Stehлік J.	

DRAWING No.:	4J9935Aa	TYPE:	CPEFS 23-7,2/250-C2	CHECKED:	Prokopec M.
				DATE:	28.4.2015

	ZEZ SILKO s.r.o. Žamberk CZECH REPUBLIC	ZEZ SILKO s.r.o. Pod černym lesem 683 564 01 Žamberk Czech Republic	tel.: +420 465 673 111 fax.: +420 465 612 319 e-mail: zez@zez-silko.cz http:// www.zez-silko.cz
--	--	--	--