

1.25Gbp/sSFP Bi-Di Transceiver

Features:

- Up to 1.25Gbps data link
- Integrated single fiber bi-directional optical subassembly
- Hot- pluggable SFP footprint
- LC pluggable optical interface
- Low power dissipation
- Metal enclosure, for lower EMI
- Single +3.3V power supply
- Optional 20/40/60km transmission distance on 9/125um SMF
- Optional operating temperature range: 0~+70°C/-40~85°C
- RoHS compliant and lead-free
- Compliant with SFF-8472

Applications:

- Gigabit Ethernet
- Gigabit Fiber Channel
- Switch to Switch Interface

Standard:

- Compliant with SFP MSA (INF-8074i)
- Compliant with SFF-8472 v12.2
- Compliant with IEEE802.3z Gigabit Ethernet

Absolute Maximum Ratings

Parameter	Symbol	Min	Typ	Max	Unit	note
Storage Temperature	Ts	-40		85	°C	
Storage Ambient Humidity	HA	5		95	%	
Power Supply Voltage	VCC	-0.5		4	V	

Recommended Operating Conditions

Parameter	Symbol	Unit	Min	Typ.	Max	Note
Case Operating Temperature Range	Tc	°C	0		70	C-Temp
			-40		85	I-Temp
Power Supply Voltage	Vcc	V	3.135	3.3	3.465	
Data Rate	-	Gb/s	-	1.25	-	

Specifications (Tc=25°C, BOL, unless otherwise noted)

Parameter	Symbol	Unit	Min	Typ	Max	Notes
Electrical Characteristics						
Supply Current	Icc	mA	-	-	300	
Single Ended Data Input Swing	-	mV	-	-	1100	
Single Ended Data Output Swing	-	mV	300	-	600	
TX_fault /LOS output (TTL)	VOH	V	2.0		Vcc	
	VOL		0		0.8	
TX_disable input (TTL)	VOH	V	2.0		Vcc	
	VOL		0		0.8	
Optical transmitter Characteristics						
Launch Optical Power	Po	dBm	-9		-3	20km
			-5		0	40km
			-2		+3	60km
Center Wavelength	λ_c	nm	1260	1310	1360	Tx1310nm 20km
			1290	1310	1330	Tx1310nm 40/60km
			1520	1550	1580	Tx1550nm
Spectral Width(RMS)	$\Delta\lambda$	nm			4	20kmFP LD
Spectral Width(20dB)	$\Delta\lambda$	nm			1	DFB LD
Side Mode Suppression Ratios	SMSR	dB	30			DFB LD
Extinction Ratio	ER	dB	9			
Eye Diagram	Complies with IEEE802.3z eye masks when filtered					
Pout of OFF transmitter	Poff	dBm	-	-	-40	
Optical receiver Characteristics						
Center Wavelength Range	λ_c	nm	1480		1610	Tx1310nm
			1260		1360	Tx1550nm

WMGP-B2CxxNx/ WMGP-BC2xxNx

Receiver Sensitivity 1	Sen	dBm			-24	20~40km
					-26	60km
Overload Input Optical Power	Psat	dBm	-3			
LOS De-assert	LosD	dBm			-25	
LOS Assert	LosA		-38			
LOS Hysteresis		dB	0.5	3	5	2

Notes:

1. Measured with a PRBS 2²³-1 test pattern, @1.25Gb/s, EX=10dB, BER<10⁻¹²
2. The LOS Hysteresis to minimize "chatter" on the output line. In principle, hysteresis alone does not guarantee chatter-free operation

Monitoring Interface

Parameter	Symbol	Spec	Units	Conditions / Notes
Temperature		+/-3°C	°C	
Voltage		+/-5%	V	
IBias		+/-10%	mA	
Rx power		+/-2	dBm	@25°C
Tx power		+/-2	dBm	@25°C

Typical Application Circuit

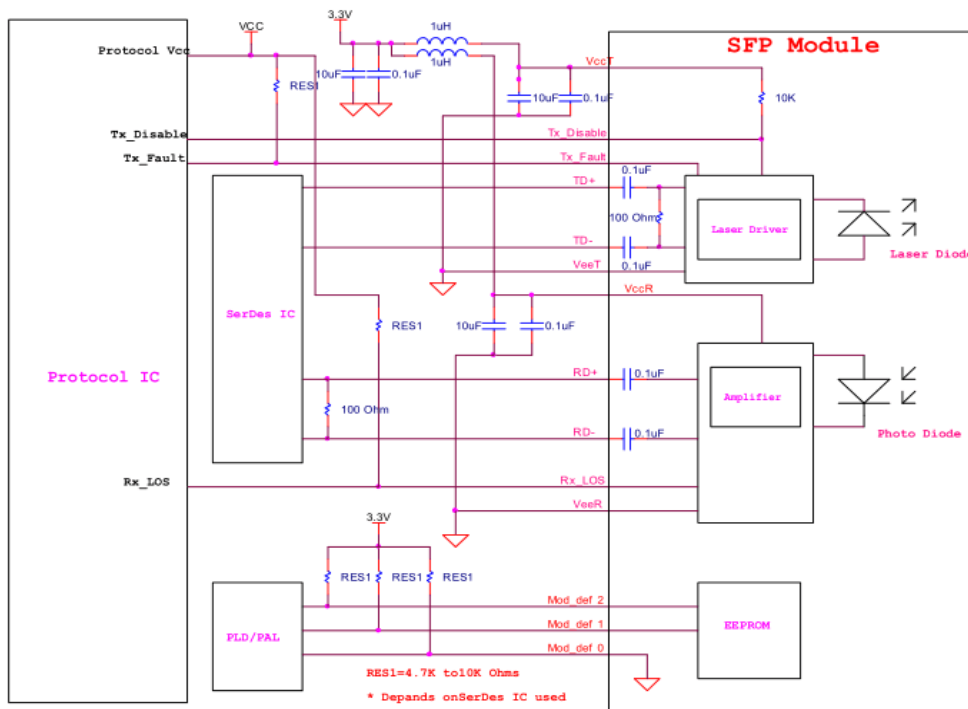

Pin Descriptions

Pin	Name	Function/Description	Engagement order	Notes
1	VeeT	Transmitter Ground	1	
2	TX Fault	Transmitter Fault Indication	3	1
3	TX Disable	Transmitter Disable-Module disables on high or open	3	2
4	MOD_DEF2	Module Definition 2-Two wire serial ID interface	3	3
5	MOD_DEF1	Module Definition 1-Two wire serial ID interface	3	3
6	MOD_DEF0	Module Definition 0-Two wire serial ID interface	3	3
7	Rate Select	Not Connected	3	
8	LOS	Loss of Signal	3	4
9	VeeR	Receiver Ground	1	
10	VeeR	Receiver Ground	1	
11	VeeR	Receiver Ground	1	
12	RD-	Inverse Received Data out	3	5
13	RD+	Received Data out	3	5
14	VeeR	Receiver Ground	1	
15	VccR	Receiver Power --- +3.3V±5%	2	6
16	VccT	Transmitter Power --- +3.3 V±5%	2	6
17	VeeT	Transmitter Ground	1	
18	TD+	Transmitter Data In	3	7
19	TD-	Inverse Transmitter Data In	3	7
20	VeeT	Transmitter Ground	1	

Notes:

- TX Fault is open collector/drain output which should be pulled up externally with a 4.7K -10KΩ resistor on the host board to supply $V_{ccT}+0.3V$ or $V_{ccR}+0.3V$. When high, this output indicates a laser fault of some kind. Low indicates normal operation. In the low state, the output will be pulled to <math><0.8V</math>.
- TX Disable input is used to shut down the laser output per the state table below. It is pulled up within the module with a 4.7-10K resistor.
 Low (0-0.8V): Transmitter on
 Between (0.8V and 2V): Undefined
 High (2.0-VccT): Transmitter Disabled
 Open : Transmitter Disabled
- Mod-Def 0, 1, 2. These are the module definition pins. They should be pulled up with a 4.7 -10K resistor on the host board to supply less than $V_{ccT}+0.3V$ or $V_{ccR}+0.3V$.
 Mod-Def 0 is grounded by the module to indicate that the module is present.
 Mod-Def 1 is clock line of two wire serial interface for optional serial ID.
 Mod-Def 2 is data line of two wire serial interface for optional serial ID.
- LOS (Loss of signal) is an open collector/drain output which should be pulled up externally with a 4.7-10K resistor on the host board to supply $V_{ccT}+0.3V$ or $V_{ccR}+0.3V$. When high, this output indicates the received

WMGP-B2CxxNx/ WMGP-BC2xxNx

optical power is below the worst case receiver sensitivity (as defined by the standard in use). Low indicates normal operation. In the low state, the output will be pulled to $<0.8V$.

5. RD-/+ : These are the differential receiver outputs. They are AC coupled 100Ω differential lines which should be terminated with 100Ω differential at the user SERDES. The AC coupling is done inside the module and thus not required on the host board.
6. VccR and VccT are the receiver and transmitter power supplies. They are defined as $3.3V\pm 5\%$ at the SFP connector pin. The in-rush current will typically be no more than 30Ma above steady state supply current after 500ns.
7. TD-/+ : These are the differential transmitter inputs. They are AC coupled differential lines with 100Ω differential termination inside the module. The AC coupling is done inside the module and is thus not required on host board

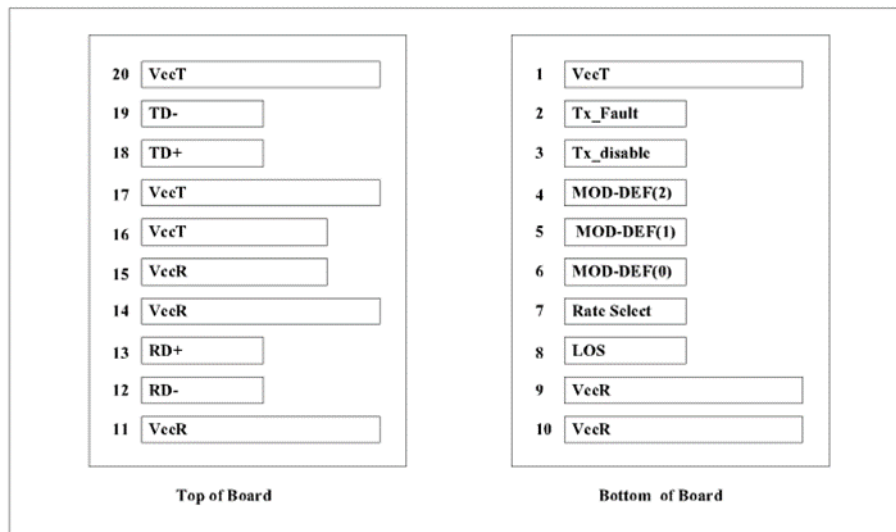

As Viewed Through Top of Board

Mechanical Specifications (Unit: mm)

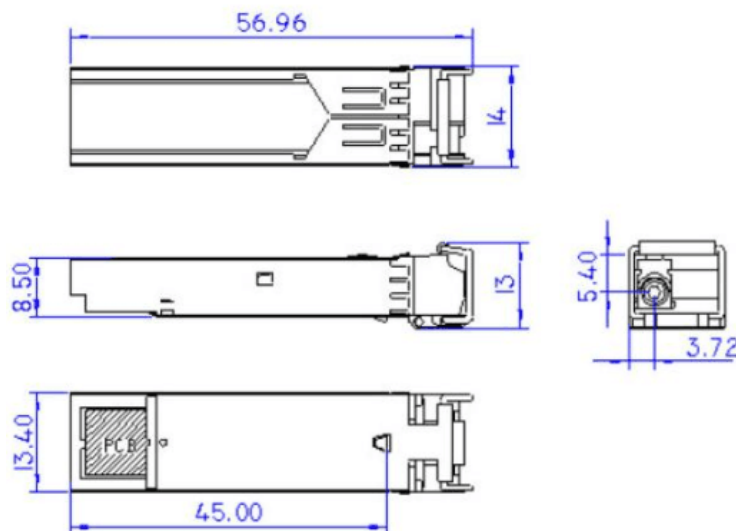

Notes:

1. Tolerance: $\pm 0.1mm$.
2. Others are according with SFF-8074i/SFF-8432 MSA or customer SPEC.
3. Light port according with fiber connector SPEC.

Regulatory Compliance

Feature	Test Method	Performance
Electrostatic Discharge (ESD) to the Electrical Pins	MIL-STD-883C Method 3015.7	Class 1 (> 1500 Volts)
Electrostatic Discharge (ESD) Immunity	Variation of IEC 61000-4-2	LV4(Air discharge :15KV Contact discharge:8 KV Performance criterion:B
Electromagnetic Interference (EMI)	CISPR22 ITE Class B EN55022 Class B FCC Class B	Compliant with standards
Immunity	IEC61000-4-3 Class 2 EN55024	Typically show no measurable effect from a 3V/m field swept from 80 to 1000MHz applied to the transceiver without a chassis enclosure.

Ordering Information

Part. No	Specifications								
	Rate Gb/s	Tx	Tx WL nm	Po dBm	Rx	Sen. dBm	Top °C	Reach km	Other
WMGP-B2CL1NC	1.25	FPLD	1310	-9~-3	PIN	<-24	0~70	20	RoHS
WMGP-BC2L1NC	1.25	DFBLD	1550	-9~-3	PIN	<-24	0~70	20	RoHS
WMGP-B2CL1NI	1.25	FPLD	1310	-9~-3	PIN	<-24	-40~85	20	RoHS
WMGP-BC2L1NI	1.25	DFBLD	1550	-9~-3	PIN	<-24	-40~85	20	RoHS
WMGP-B2CERNC	1.25	DFBLD	1310	-5~0	PIN	<-24	0~70	40	RoHS
WMGP-BC2ERNC	1.25	DFBLD	1550	-5~0	PIN	<-24	0~70	40	RoHS
WMGP-B2CERNI	1.25	DFBLD	1310	-5~0	PIN	<-24	-40~85	40	RoHS
WMGP-BC2ERNI	1.25	DFBLD	1550	-5~0	PIN	<-24	-40~85	40	RoHS
WMGP-B2CE1NC	1.25	DFBLD	1310	-2~+3	PIN	<-26	0~70	60	RoHS
WMGP-BC2E1NC	1.25	DFBLD	1550	-2~+3	PIN	<-26	0~70	60	RoHS
WMGP-B2CE1NI	1.25	DFBLD	1310	-2~+3	PIN	<-26	-40~85	60	RoHS
WMGP-BC2E1NI	1.25	DFBLD	1550	-2~+3	PIN	<-26	-40~85	60	RoHS

Warnings

Handling Precautions:

This device is susceptible to damage as a result of electrostatic discharge (ESD). A static free environment is highly recommended. Please follow guidelines according to proper ESD procedures.

Laser Safety:

Radiation emitted by laser devices can be dangerous to human eyes. Avoid eye exposure to direct or indirect radiation.

Notice:

The information provided on this page contains the product target specifications which are subject to change without notice. For more information, please check with your Neowave Sales Office for product updates, changes in specifications, sample availability and products release dates.

Sales Head office:

Wuhan Neowave Optics Co., Ltd.

Add: Floor 7, Building#11, Guanggu New Power Industry Zone, No.219 Guanggu Second Road, East Lake Development Zone, Wuhan, China

Postal Code: 430223

Tel: 027-65520906

Website: www.neowave-optics.com

Email: sales@neowave-optics.com